

e

d

c

b

a

ITEM	DESCRIPTION	MATL	QUANTITY
1	Quartz Window Sleeve Pipe	ALUM	1
2	Quartz Window Sleeve Plate	ALUM	1

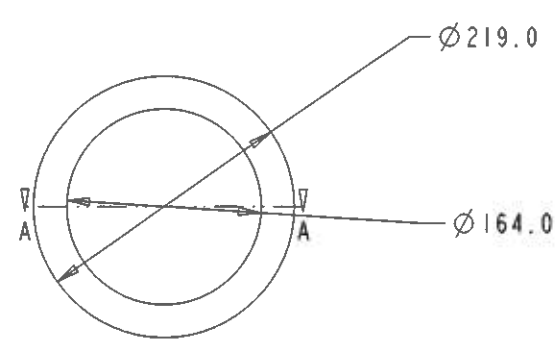
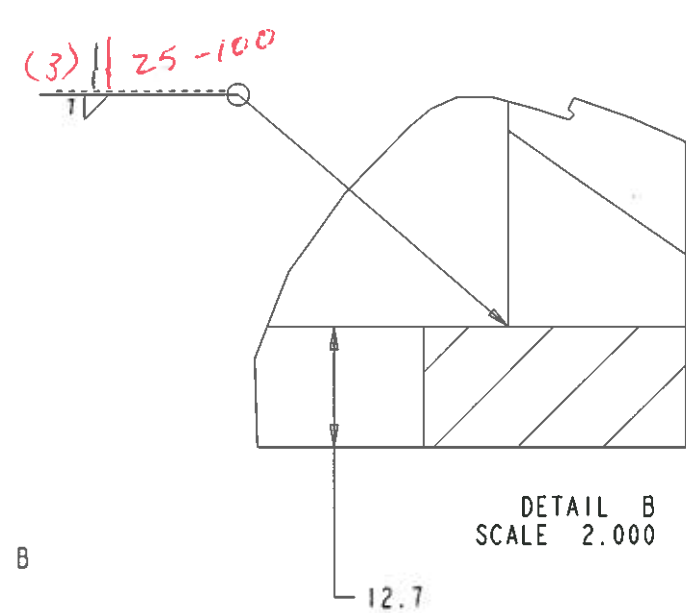
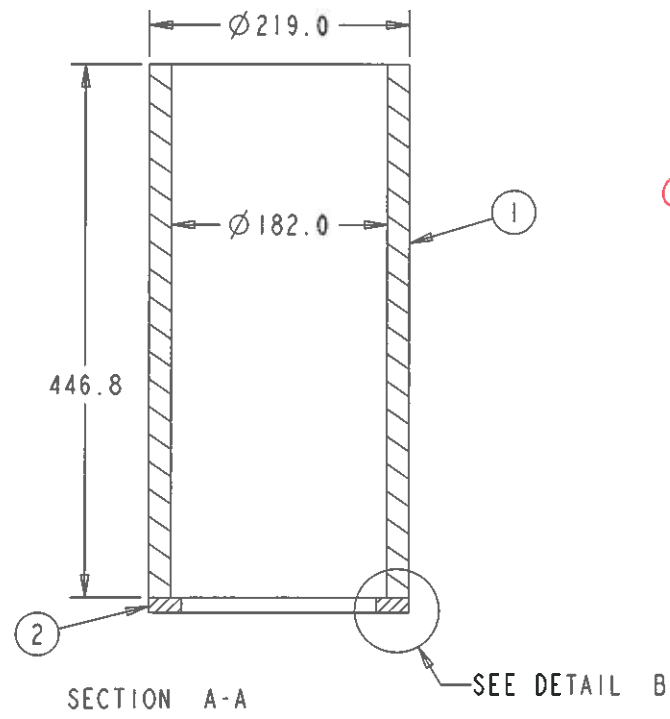

NOTES:

- 1 WILL BE A 8" SCH 140 PIPE WITH ID BORED TO PROPER DIMENSION
- 2 WILL BE MADE FROM AN ALUMINUM PLATE

*TYPE ?  
LOOK!*

ALL DIMENSIONS IN mm UNLESS OTHERWISE SPECIFIED  
 TOLERANCES UNLESS OTHERWISE SPECIFIED:  
 FRACTIONAL DIMENSIONS  
 DECIMAL DIMENSIONS X ± .1 XX ± .05  
 ANGULAR DIMENSIONS ± 1°  
 SURFACE FINISH 32um

**UNIVERSITY OF ALBERTA**  
 EDMONTON ALBERTA CANADA

DESIGNED CHRIS NG TELEPHONE (780) 492 3095  
 DRAWN CHRIS NG FAX (780) 492 3408  
 CHECKED E-MAIL: cjang@ualberta.ca

APPROVED

REF. DWGS	REV.	DATE	REVISION	BY

**CENTER OF PARTICLE PHYSICS**

QUARTZ WINDOW SLEEVE WELDED BEFORE MACHINING

SCALE 0.250 APPROVAL DWG. NO. REV.  
 DATE JAN 6. 2012 CHIEF ENGR

e

d

c

b

a