

3
2
1

e

d

c

b

a

ITEM	DESCRIPTION	MAT'L	QUANTITY

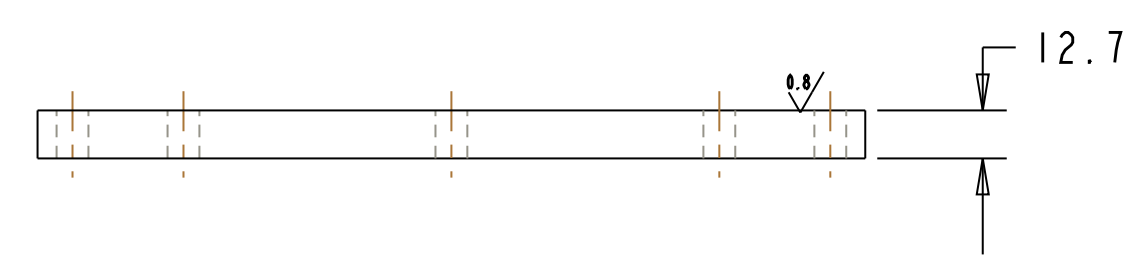
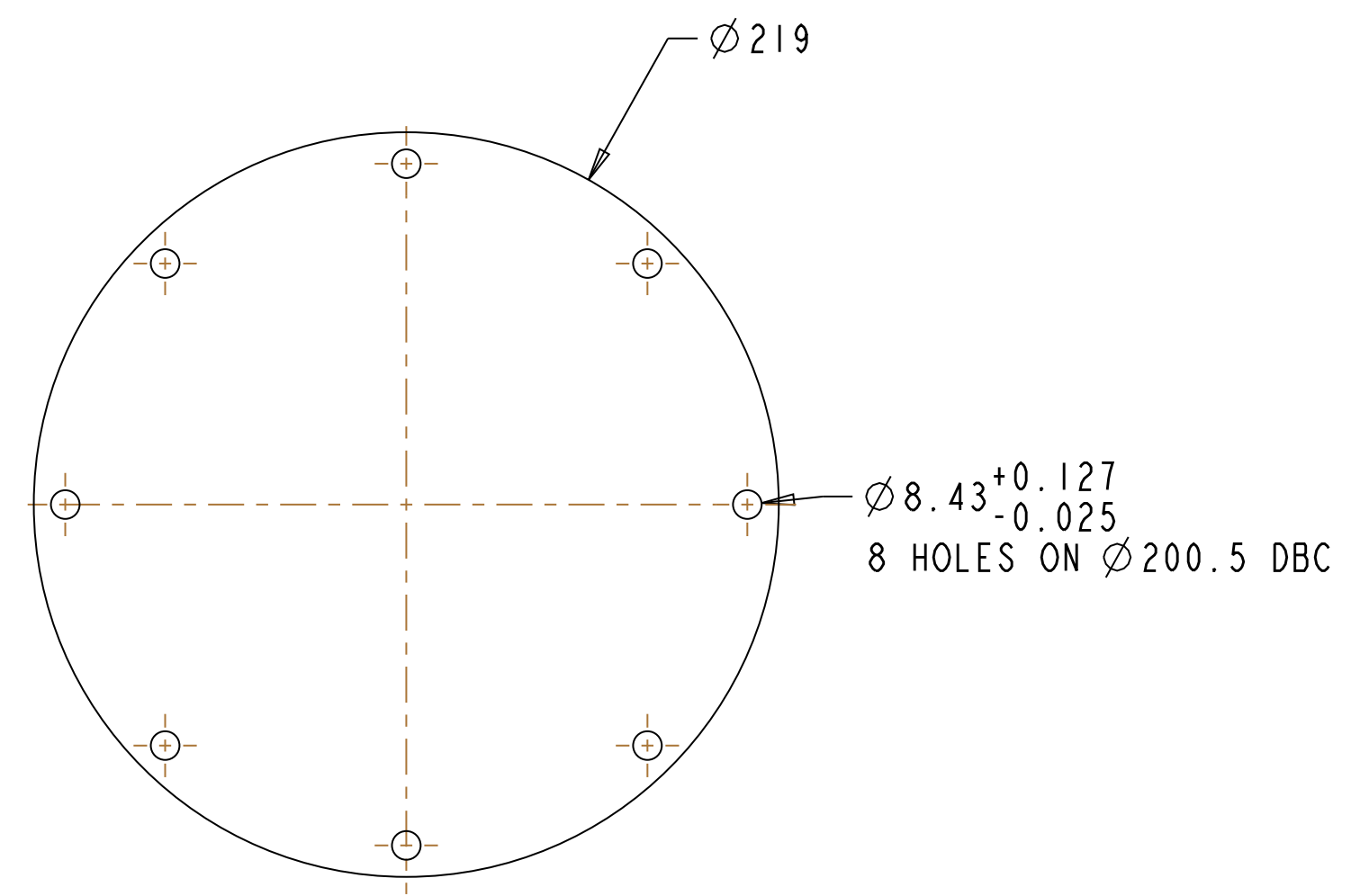

MATL: 0.5" STEEL PLATE

ALL DIMENSIONS IN mm UNLESS OTHERWISE SPECIFIED
 TOLERANCES UNLESS OTHERWISE SPECIFIED:
 FRACTIONAL DIMENSIONS
 DECIMAL DIMENSIONS XX ± 0.5
 ANGULAR DIMENSIONS ± 0.5°
 SURFACE FINISH MILL FINISH

UNIVERSITY OF ALBERTA
 EDMONTON ALBERTA CANADA

DESIGNED CHRIS NG TELEPHONE (780) 492 5979
 DRAWN CHRIS NG FAX (780) 492 3408
 CHECKED E-MAIL: cjng@ualberta.ca

APPROVED

REF. DWGS.	REV.	DATE	REVISION	BY
	B		FIXED TOLERANCES	

CENTER OF PARTICLE PHYSICS

QUARTZ WINDOW BLANK OFF

SCALE 0.500 APPROVAL DWG. NO REV.
 DATE APR 17, 2012 CHIEF ENGR B

e

d

c

b

a