

ITEM	DESCRIPTION	MAT'L	QUANTITY

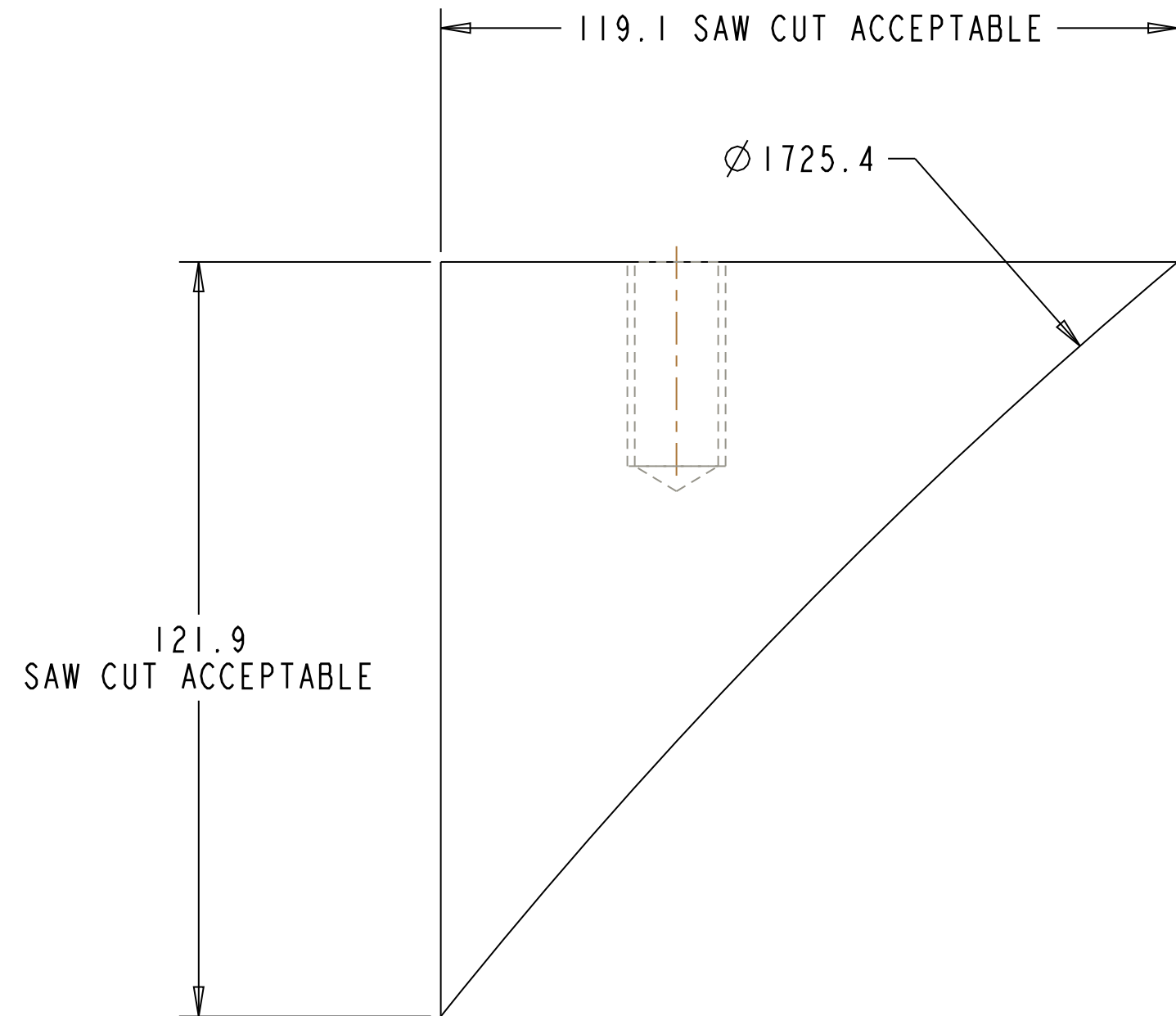

MATL: ALUM 6061-T6

ALL DIMENSIONS IN mm UNLESS OTHERWISE SPECIFIED
 TOLERANCES UNLESS OTHERWISE SPECIFIED:
 FRACTIONAL DIMENSIONS
 DECIMAL DIMENSIONS XX ± 0.5
 ANGULAR DIMENSIONS ± 0.5°
 SURFACE FINISH MILL FINISH

REF. DWGS.	REV.	DATE	REVISION	BY

UNIVERSITY OF ALBERTA
 EDMONTON ALBERTA CANADA

DESIGNED CHRIS NG TELEPHONE (780) 492 5979
 DRAWN CHRIS NG FAX (780) 492 3408
 CHECKED E-MAIL: cjng@ualberta.ca

APPROVED

CENTER OF PARTICLE PHYSICS

LIFTING LUG

SCALE 1.000 APPROVAL DWG. NO. REV.
 DATE MAR 1, 2012 CHIEF ENGR