

ITEM	DESCRIPTION	MAT'L	QUANTITY
1	Quartz Window Sleeve Pipe Long	ALUM	1
2	Quartz Window Sleeve Plate	ALUM	1

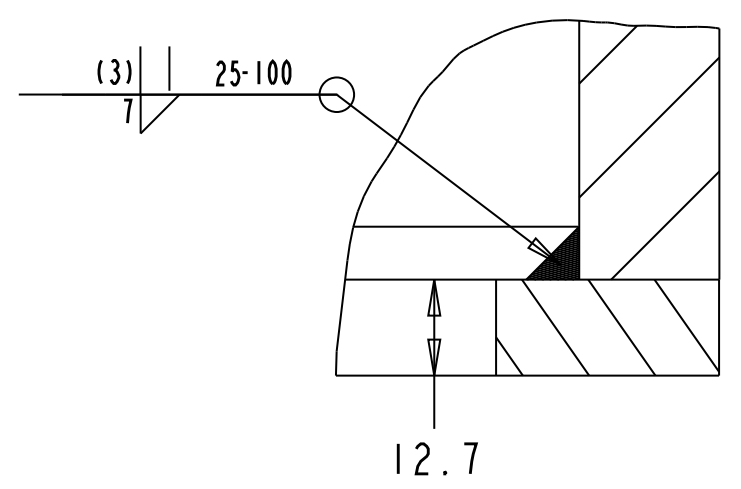
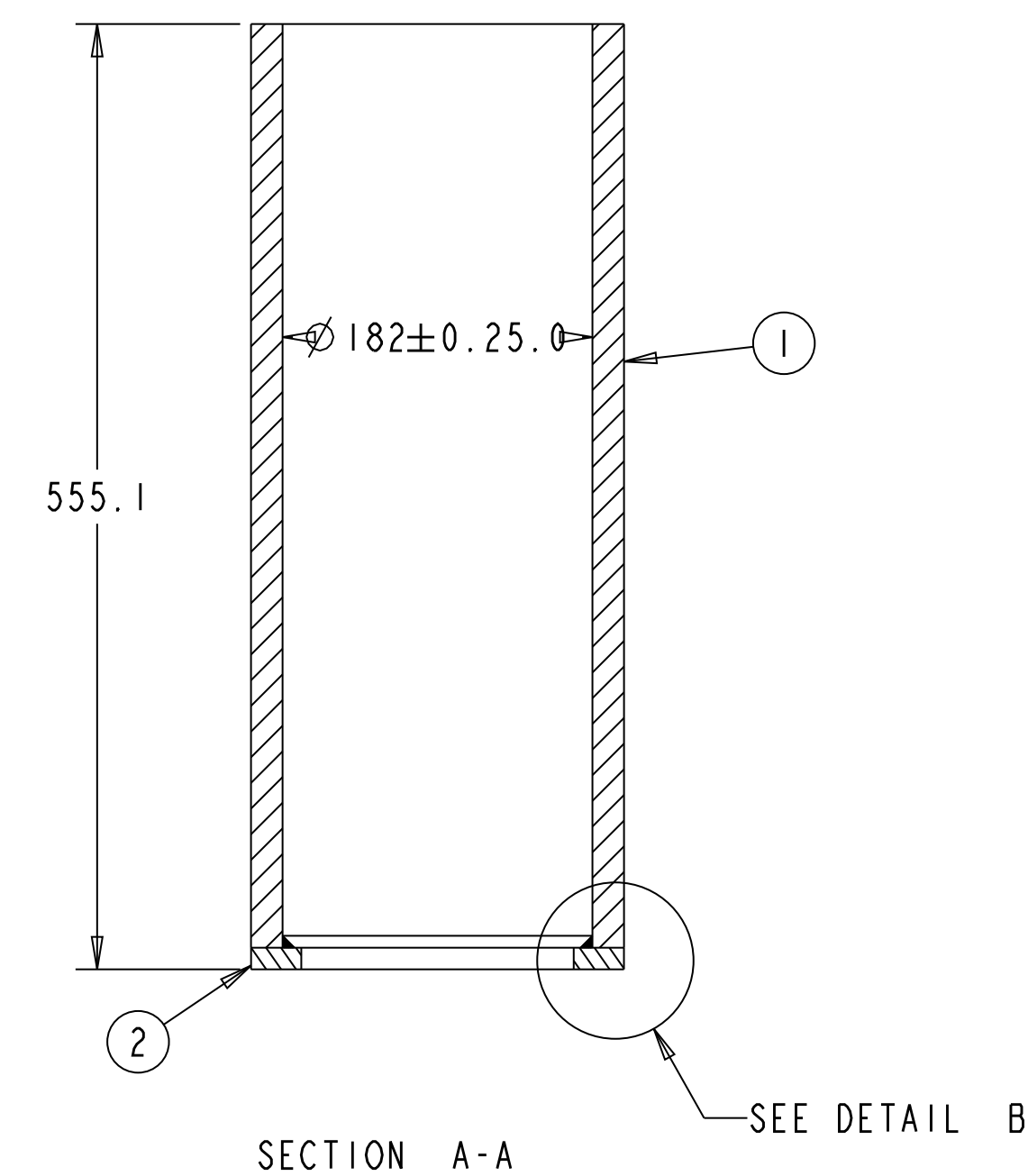

DETAIL B
SCALE 1.000

NOTES:

- 1 WILL BE A 8" SCH 140 ALUMINUM 6061 T-6 PIPE WITH ID BORED TO PROPER DIMENSION
- 2 WILL BE MADE FROM A 0.5" ALUMINUM 6061 T-6 PLATE

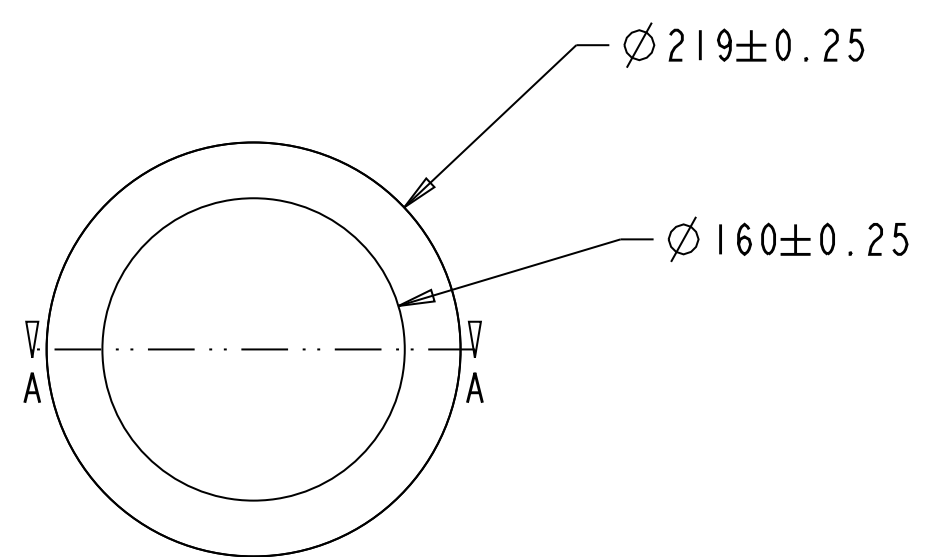

ALL DIMENSIONS IN mm UNLESS OTHERWISE SPECIFIED
 TOLERANCES UNLESS OTHERWISE SPECIFIED:
 FRACTIONAL DIMENSIONS
 DECIMAL DIMENSIONS X ± .1 XX ± .05
 ANGULAR DIMENSIONS ± 1°
 SURFACE FINISH 32µm

REF. DWGS.	REV.	DATE	REVISION	BY

UNIVERSITY OF ALBERTA
 EDMONTON ALBERTA CANADA

DESIGNED CHRIS NG TELEPHONE (780) 492 5979
 DRAWN CHRIS NG FAX (780) 492 3408
 CHECKED E-MAIL: cjng@ualberta.ca

APPROVED

CENTER OF PARTICLE PHYSICS

QUARTZ WINDOW SLEEVE LONG
 WELDED BEFORE MACHINING

SCALE 0.250 APPROVAL DWG. NO. REV.
 DATE MAR 1. 2012 CHIEF ENGR

3

2

1

